

Client:	BLOOR HOMES
Site:	BLOOR 2022
House Type:	CLASSIC 481 HARWOOD - EXC UTILITY
House Type 2:	STANDARD

Drawing No:	724212_A
Revision No:	A
Scale:	Scale-to-fit



THIS DRAWING AND THE COPYRIGHT THEREIN IS THE PROPERTY OF THE SYMPHONY GROUP PLC. THIS DRAWING IS ISSUED ON THE CONDITION THAT IT MUST NOT BE USED, COPIED OR EXHIBITED WITHOUT THE WRITTEN PERMISSION OF THE SYMPHONY GROUP PLC. ANY COMPONENTS OR ARTICLES MADE IN ACCORDANCE WITH THIS DRAWING MUST NOT BE USED FOR ANY OTHER PURPOSE THAN FOR WHICH THE DRAWING IS ISSUED.

THIS PLAN IS OFFERED AS A GUIDE ONLY FOR APPROVAL BY OUR CUSTOMER. NO RESPONSIBILITY IS UNDERTAKEN FOR ITS ACCURACY IN RELATION TO ORDERS PLACED FOR THE FITTING OF OUR GOODS WITHIN THE DIMENSIONS SHOWN.

**SCHEDULE &  
CUBIC CAPACITY**



Client Name:	BLOOR HOMES	Site Name:	BLOOR 2022 CLASSIC ISSUE 4
House Type:	CLASSIC 481 HARWOOD - EXC UTILITY STANDARD		
Drawing No:	724212_A	Revision No:	A
Date Drawn:	Fri, Jul 15, 2022	Revision Date:	14.7.22
Designed By:	CARA NORTCLIFF	Quote No:	

Items on Plan:

Default Style

Plan No.	Qty	Code	Hdg	Description	Dims	CC (M3)
1	1	BU56F	L	Base Unit FH	500/600/870	0.16
2	1	BU66F3IDC	R	Base Unit FH w/1x Shallow Int. Drw & 2x Deep Int. Drw	600/600/870	0.20
3	1	BU56F	R	Base Unit FH	500/600/870	0.16
4	1	OH663A	R	Dbl Oven Hsg. (3A)	600/600/2100	0.28
5	1	LU66	L	Larder Unit (70/30 Split)	600/600/2100	0.52
6	1	BU66F	L	Base Unit FH	600/600/870	0.20
7	1	SU66SLF	L	Sink Unit FH w/Sink Liner	600/600/870	0.20
8	1	BU66F	R	Base Unit FH	600/600/870	0.20
9	1	BU456F	L	Base Unit FH	450/600/870	0.14
10	1	BU66F	R	Base Unit FH	600/600/870	0.20
11	1	BU456F	R	Base Unit FH	450/600/870	0.14
12	1	BBBP992C		Carcase Matched Breakfast Bar Back Panel	900/920	
13	1	BU453F	L	Reduced Depth Base Unit FH	450/300/870	0.07
14	1	BU63F	L	Reduced Depth Base Unit FH	600/300/870	0.10
15	1	BU453F	R	Reduced Depth Base Unit FH	450/300/870	0.07
16	1	BBBP992C		Carcase Matched Breakfast Bar Back Panel	900/920	
17	1	WU472	L	Wall Unit	400/300/724	0.07
18	1	WU472	R	Wall Unit	400/300/724	0.07
19	1	WU672	L	Wall Unit	600/300/724	0.10
20	1	WU672	R	Wall Unit	600/300/724	0.10
21	1	WU672	L	Wall Unit	600/300/724	0.10
22	1	WU672	R	Wall Unit	600/300/724	0.10
	1	HOBSHIELD6		Hobshield	600	
	1	BWU390C		Carcase Matched Wall Blender (For Filler)	307/920	
	1	CONPLINTHC		Carcase Matched Continuous Plinth (For Tall Filler)	2600	

**Total cubic metres of storage 3.18**

Worktop Details: Default Style

<b>Plan No.</b>	<b>Qty</b>	<b>Code</b>	<b>Description</b>	<b>Dims</b>
23	1	PWT	40mm PVC Edged / 40mm Premium / 30mm Hi Def Worktop	1610/600
24	1	PWT	40mm PVC Edged / 40mm Premium / 30mm Hi Def Worktop	2500/600
25	1	DPWT	40mm Double PVC Edged / 40mm Premium / 30mm Hi Def Worktop	1556/900
	1	PFUP3095	Laminate Upstand	3050/95
	1	PFUP3095	Laminate Upstand	3050/95

Accessories and Trims:

Default Style

<b>Qty</b>	<b>Code</b>	<b>Description</b>	<b>Dims</b>
2	BRKPLINTH	Plinth Corner Bracket (Pack of 2)	
4	CONPLINTHC	Carcase Matched Continuous Plinth w/Plinth Seal	2600
1	CTRAYVFH6	Standard Internal Cutlery Tray (For BU66F3ID/BU66F4ID)	600
2	FITFACTOR	FITFACTOR	
2	RUNITPROTECT	Kitchen Protective Material	
1	STSBACK600	Stainless Steel Splashback 600 X	750
1	VENTGRILL200	Ventilation Grill - Flowrate	200cm2

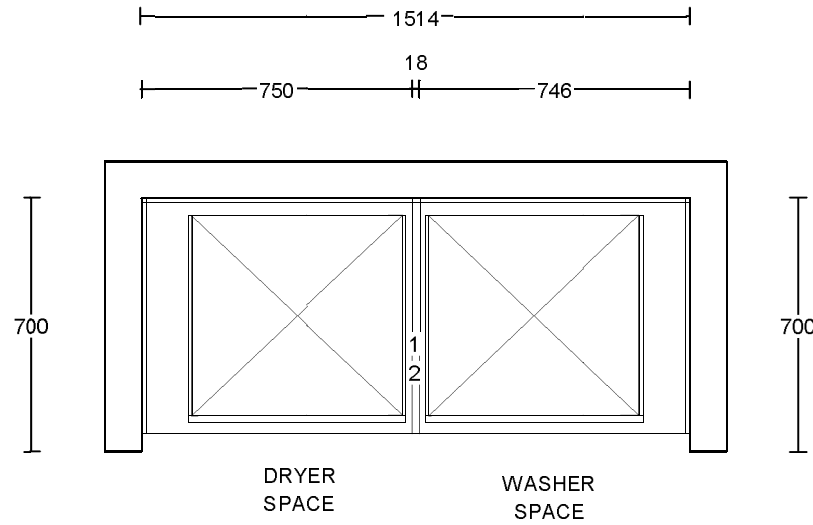

650mm DEEP WORKTOPS

PLEASE CHECK &  
CONFIRM DIMENSIONS  
& LAYOUT ON SITE  
BEFORE ORDERING  
CABINETS

Client:	BLOOR HOMES	Drawing No:	724212U_	<b>Symphony</b> <sup>®</sup>
Site:	BLOOR 2022	Revision No:		
House Type:	CLASSIC 481 HARWOOD - UTILITY	Scale:	Scale-to-fit	
House Type 2:	STANDARD			

THIS DRAWING AND THE COPYRIGHT THEREIN IS THE PROPERTY OF THE SYMPHONY GROUP PLC. THIS DRAWING IS ISSUED ON THE CONDITION THAT IT MUST NOT BE USED, COPIED OR EXHIBITED WITHOUT THE WRITTEN PERMISSION OF THE SYMPHONY GROUP PLC. ANY COMPONENTS OR ARTICLES MADE IN ACCORDANCE WITH THIS DRAWING MUST NOT BE USED FOR ANY OTHER PURPOSE THAN FOR WHICH THE DRAWING IS ISSUED.

THIS PLAN IS OFFERED AS A GUIDE ONLY FOR APPROVAL BY OUR CUSTOMER. NO RESPONSIBILITY IS UNDERTAKEN FOR ITS ACCURACY IN RELATION TO ORDERS PLACED FOR THE FITTING OF OUR GOODS WITHIN THE DIMENSIONS SHOWN.

**SCHEDULE &  
CUBIC CAPACITY**



Client Name:	BLOOR HOMES	Site Name:	BLOOR 2022 2018 - LEVEL 2 ISSUE 4
House Type:	CLASSIC 481 HARWOOD - UTILITY STANDARD		
Drawing No:	724212U_	Revision No:	
Date Drawn:	Fri, Nov 25, 2022	Revision Date:	
Designed By:	CARA NORTCLIFF	Quote No:	

Items on Plan: Default Style

Plan No.	Qty	Code	Hdg	Description	Dims	CC (M3)
1	1	BBU6592C		Carcase Matched Base Blender	650/920	

**Total cubic metres of  
storage**

Worktop Details: Default Style

Plan No.	Qty	Code	Description	Dims
2	1	PWT	40mm PVC Edged / 40mm Premium / 30mm Hi Def Worktop	1600/650
	1	PFUP3095	Laminate Upstand	3050/95

Accessories and Trims: Default Style

Qty	Code	Description	Dims
1	RUNITPROTECT	Kitchen Protective Material	

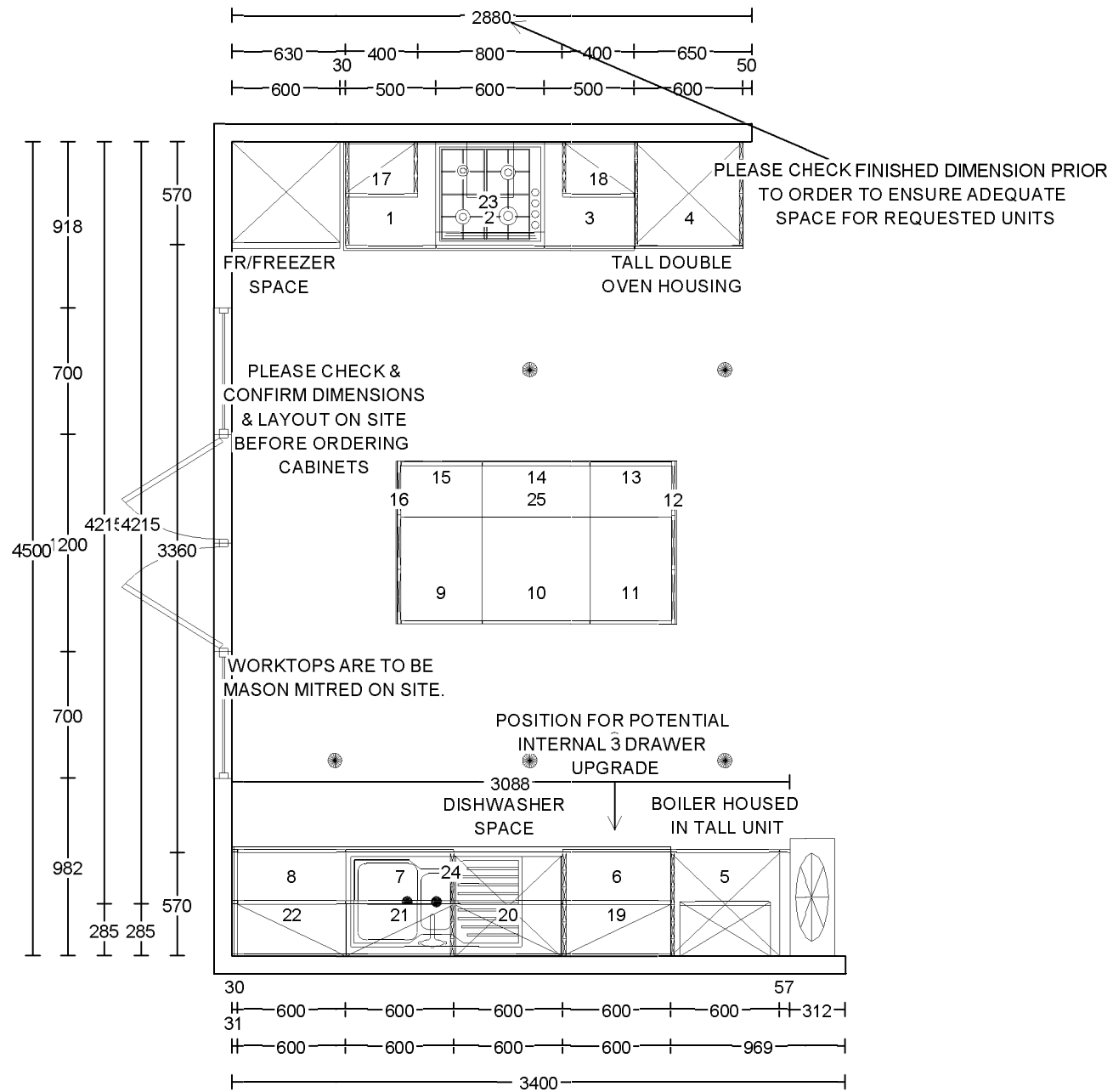

Client:	BLOOR HOMES
Site:	BLOOR 2022
House Type:	CLASSIC 481 HARWOOD - EXC UTILITY
House Type 2:	UPGRADE

Drawing No:	724214_A
Revision No:	A
Scale:	Scale-to-fit

**Symphony**

THIS DRAWING AND THE COPYRIGHT THEREIN IS THE PROPERTY OF THE SYMPHONY GROUP PLC. THIS DRAWING IS ISSUED ON THE CONDITION THAT IT MUST NOT BE USED, COPIED OR EXHIBITED WITHOUT THE WRITTEN PERMISSION OF THE SYMPHONY GROUP PLC. ANY COMPONENTS OR ARTICLES MADE IN ACCORDANCE WITH THIS DRAWING MUST NOT BE USED FOR ANY OTHER PURPOSE THAN FOR WHICH THE DRAWING IS ISSUED.

THIS PLAN IS OFFERED AS A GUIDE ONLY FOR APPROVAL BY OUR CUSTOMER. NO RESPONSIBILITY IS UNDERTAKEN FOR ITS ACCURACY IN RELATION TO ORDERS PLACED FOR THE FITTING OF OUR GOODS WITHIN THE DIMENSIONS SHOWN.

**SCHEDULE &  
CUBIC CAPACITY**



Client Name:	BLOOR HOMES	Site Name:	BLOOR 2022 CLASSIC ISSUE 4
House Type:	CLASSIC 481 HARWOOD - EXC UTILITY UPGRADE		
Drawing No:	724214_A	Revision No:	A
Date Drawn:	Fri, Jul 15, 2022	Revision Date:	14.7.22
Designed By:	CARA NORTCLIFF	Quote No:	

Items on Plan:

Default Style

Plan No.	Qty	Code	Hdg	Description	Dims	CC (M3)
1	1	BU56FGL	L	Base Unit FH (LH End)	500/600/870	0.16
2	1	BU66F3IDC	R	Base Unit FH w/1x Shallow Int. Drw & 2x Deep Int. Drw	600/600/870	0.20
3	1	BU56F	R	Base Unit FH	500/600/870	0.16
4	1	OH663AG2	R	Dbl Oven Hsg. (3A) (2 Ends)	600/600/2100	0.28
5	1	LU66GR	L	Larder Unit (70/30 Split) (RH End)	600/600/2100	0.52
6	1	BU66FGR	L	Base Unit FH (RH End)	600/600/870	0.20
7	1	SU66SLFGL	L	Sink Unit FH w/Sink Liner (LH End)	600/600/870	0.20
8	1	BU66F	R	Base Unit FH	600/600/870	0.20
9	1	BU456F	L	Base Unit FH	450/600/870	0.14
10	1	BU66F	R	Base Unit FH	600/600/870	0.20
11	1	BU456F	R	Base Unit FH	450/600/870	0.14
12	1	BBBP992R		Replacement End Matched Breakfast Bar Back Panel	900/920	
13	1	BU453F	L	Reduced Depth Base Unit FH	450/300/870	0.07
14	1	BU63F	L	Reduced Depth Base Unit FH	600/300/870	0.10
15	1	BU453F	R	Reduced Depth Base Unit FH	450/300/870	0.07
16	1	BBBP992R		Replacement End Matched Breakfast Bar Back Panel	900/920	
17	1	WU472G2	L	Wall Unit (2 Ends)	400/300/724	0.07
18	1	WU472GL	R	Wall Unit (LH End)	400/300/724	0.07
19	1	WU672	L	Wall Unit	600/300/724	0.10
20	1	WU672	R	Wall Unit	600/300/724	0.10
21	1	WU672	L	Wall Unit	600/300/724	0.10
22	1	WU672	R	Wall Unit	600/300/724	0.10
	1	HOBSHIELD6		Hobshield	600	
	1	CONPLINTHR		Replacement End Matched Continuous Plinth (For Tall Filler)	2600	
	1	BWU390R		Replacement End Matched Wall Blender (For Filler)	307/970	
	1	BWU390R		Replacement End Matched Wall Blender (For Filler)	307/970	

**Total cubic metres of  
storage**

**3.18**

Worktop Details:

Default Style

<b>Plan No.</b>	<b>Qty</b>	<b>Code</b>	<b>Description</b>	<b>Dims</b>
23	1	PWT	40mm PVC Edged / 40mm Premium / 30mm Hi Def Worktop	1610/600
24	1	PWT	40mm PVC Edged / 40mm Premium / 30mm Hi Def Worktop	2500/600
25	1	DPWT	40mm Double PVC Edged / 40mm Premium / 30mm Hi Def Worktop	1556/900
	1	PFUP3095	Laminate Upstand	3050/95
	1	PFUP3095	Laminate Upstand	3050/95

Accessories and Trims:

Default Style

<b>Qty</b>	<b>Code</b>	<b>Description</b>	<b>Dims</b>
4	CONPLINTHR	Replacement End Matched Continuous Plinth w/Plinth Seal	2600
1	CTRAYVFH6	Standard Internal Cutlery Tray (For BU66F3ID/BU66F4ID)	600
2	FITFACTOR	FITFACTOR	
2	RUNITPROTECT	Kitchen Protective Material	
1	STSBACK600	Stainless Steel Splashback 600 X	750
1	VENTGRIDGR	Aeration Grid Grey	510/45/15



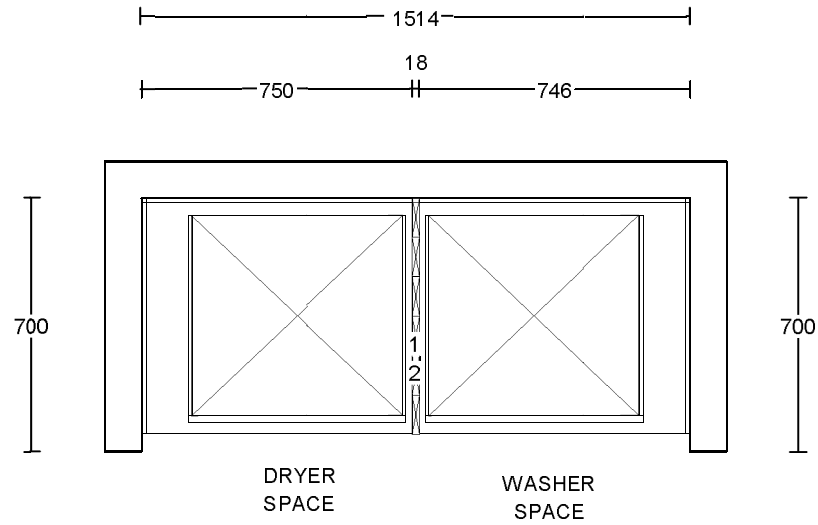

650mm DEEP WORKTOPS

PLEASE CHECK &  
 CONFIRM DIMENSIONS  
 & LAYOUT ON SITE  
 BEFORE ORDERING  
 CABINETS

Client:	BLOOR HOMES	Drawing No:	724214U_	<b>Symphony</b> <sup>®</sup>
Site:	BLOOR 2022	Revision No:		
House Type:	CLASSIC 481 HARWOOD - UTILITY	Scale:	Scale-to-fit	
House Type 2:	UPGRADE			

THIS DRAWING AND THE COPYRIGHT THEREIN IS THE PROPERTY OF THE SYMPHONY GROUP PLC. THIS DRAWING IS ISSUED ON THE CONDITION THAT IT MUST NOT BE USED, COPIED OR EXHIBITED WITHOUT THE WRITTEN PERMISSION OF THE SYMPHONY GROUP PLC. ANY COMPONENTS OR ARTICLES MADE IN ACCORDANCE WITH THIS DRAWING MUST NOT BE USED FOR ANY OTHER PURPOSE THAN FOR WHICH THE DRAWING IS ISSUED.

THIS PLAN IS OFFERED AS A GUIDE ONLY FOR APPROVAL BY OUR CUSTOMER. NO RESPONSIBILITY IS UNDERTAKEN FOR ITS ACCURACY IN RELATION TO ORDERS PLACED FOR THE FITTING OF OUR GOODS WITHIN THE DIMENSIONS SHOWN.

**SCHEDULE &  
CUBIC CAPACITY**



Client Name:	BLOOR HOMES	Site Name:	BLOOR 2022 2018 - LEVEL 2 ISSUE 4
House Type:	CLASSIC 481 HARWOOD - UTILITY UPGRADE		
Drawing No:	724214U_	Revision No:	
Date Drawn:	Fri, Nov 25, 2022	Revision Date:	
Designed By:	CARA NORTCLIFF	Quote No:	

Items on Plan:		Default Style				
Plan No.	Qty	Code	Hdg	Description	Dims	CC (M3)
1	1	BBU6592R		Replacement End Matched Base Blender	650/920	

**Total cubic metres of  
storage**

Worktop Details:		Default Style				
Plan No.	Qty	Code		Description	Dims	
2	1	PWT		40mm PVC Edged / 40mm Premium / 30mm Hi Def Worktop	1600/650	
	1	PFUP3095		Laminate Upstand	3050/95	

Accessories and Trims:		Default Style				
	Qty	Code		Description	Dims	
	1	RUNITPROTECT		Kitchen Protective Material		

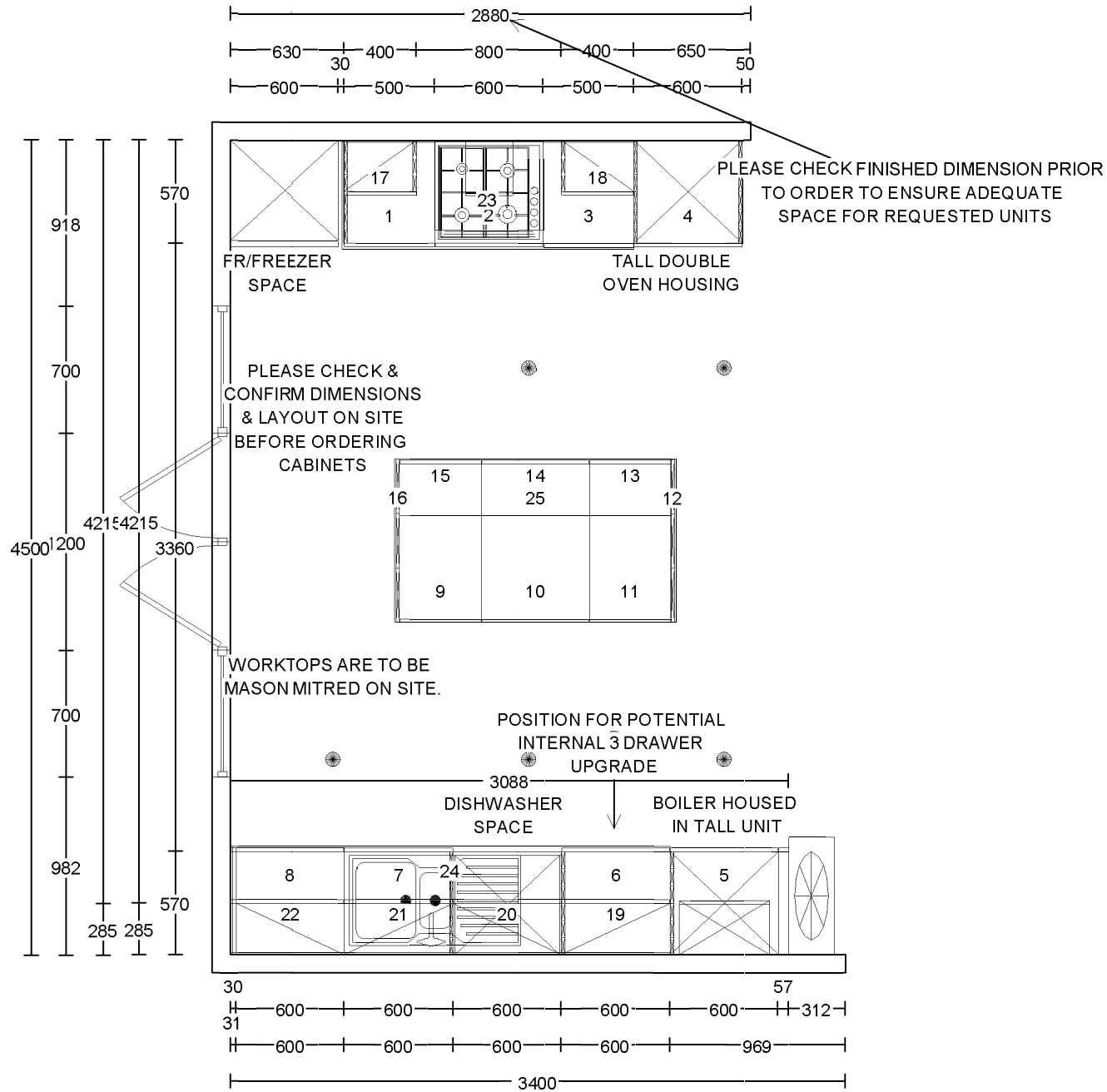

Client:	BLOOR HOMES	Drawing No:	724216__
Site:	BLOOR 2022	Revision No:	
House Type:	CLASSIC 481 HARWOOD - EXC UTILITY	Scale:	Scale-to-fit
House Type 2:	EXCLUSIVE		

**Symphony**<sup>®</sup>

**SCHEDULE &  
CUBIC CAPACITY**



Client Name:	BLOOR HOMES	Site Name:	BLOOR 2022 CLASSIC ISSUE 4
House Type:	CLASSIC 481 HARWOOD - EXC UTILITY EXCLUSIVE		
Drawing No:	724216__	Revision No:	
Date Drawn:	Wed, Mar 30, 2022	Revision Date:	
Designed By:	CARA NORTCLIFF	Quote No:	

Items on Plan:

Default Style

Plan No.	Qty	Code	Hdg	Description	Dims	CC (M3)
1	1	BU56FGL	L	Base Unit FH (LH End)	500/600/870	0.16
2	1	BU66F3IDC	R	Base Unit FH w/1x Shallow Int. Drw & 2x Deep Int. Drw	600/600/870	0.20
3	1	BU56F	R	Base Unit FH	500/600/870	0.16
4	1	OH663AG2	R	Dbl Oven Hsg. (3A) (2 Ends)	600/600/2100	0.28
5	1	LU66GR	L	Larder Unit (70/30 Split) (RH End)	600/600/2100	0.52
6	1	BU66FGR	L	Base Unit FH (RH End)	600/600/870	0.20
7	1	SU66SLFGL	L	Sink Unit FH w/Sink Liner (LH End)	600/600/870	0.20
8	1	BU66F	R	Base Unit FH	600/600/870	0.20
9	1	BU456F	L	Base Unit FH	450/600/870	0.14
10	1	BU66F	R	Base Unit FH	600/600/870	0.20
11	1	BU456F	R	Base Unit FH	450/600/870	0.14
12	1	BBBP992R		Replacement End Matched Breakfast Bar Back Panel	900/920	
13	1	BU453F	L	Reduced Depth Base Unit FH	450/300/870	0.07
14	1	BU63F	L	Reduced Depth Base Unit FH	600/300/870	0.10
15	1	BU453F	R	Reduced Depth Base Unit FH	450/300/870	0.07
16	1	BBBP992R		Replacement End Matched Breakfast Bar Back Panel	900/920	
17	1	WU472G2	L	Wall Unit (2 Ends)	400/300/724	0.07
18	1	WU472GL	R	Wall Unit (LH End)	400/300/724	0.07
19	1	WU672	L	Wall Unit	600/300/724	0.10
20	1	WU672	R	Wall Unit	600/300/724	0.10
21	1	WU672	L	Wall Unit	600/300/724	0.10
22	1	WU672	R	Wall Unit	600/300/724	0.10
	1	HOBSHIELD6		Hobshield	600	
	1	CONPLINTHR		Replacement End Matched Continuous Plinth (For Tall Filler)	2600	
	1	BWU390R		Replacement End Matched Wall Blender (For Filler)	307/970	
	1	BWU390R		Replacement End Matched Wall Blender (For Filler)	307/970	

**Total cubic metres of storage**

**3.18**

Worktop Details:

Default Style

<b>Plan No.</b>	<b>Qty</b>	<b>Code</b>	<b>Description</b>	<b>Dims</b>
23	1	PWT	40mm PVC Edged / 40mm Premium / 30mm Hi Def Worktop	1610/600
24	1	PWT	40mm PVC Edged / 40mm Premium / 30mm Hi Def Worktop	2500/600
25	1	DPWT	40mm Double PVC Edged / 40mm Premium / 30mm Hi Def Worktop	1556/900
	1	PFUP3095	Laminate Upstand	3050/95
	1	PFUP3095	Laminate Upstand	3050/95

Accessories and Trims:

Default Style

<b>Qty</b>	<b>Code</b>	<b>Description</b>	<b>Dims</b>
4	CONPLINTHR	Replacement End Matched Continuous Plinth w/Plinth Seal	2600
1	CTRAYVFH6	Standard Internal Cutlery Tray (For BU66F3ID/BU66F4ID)	600
2	FITFACTOR	FITFACTOR	
1	GLSPASH675	Glass Splashback	600/750
2	RUNITPROTECT	Kitchen Protective Material	
1	VENTGRIDGR	Aeration Grid Grey	510/45/15

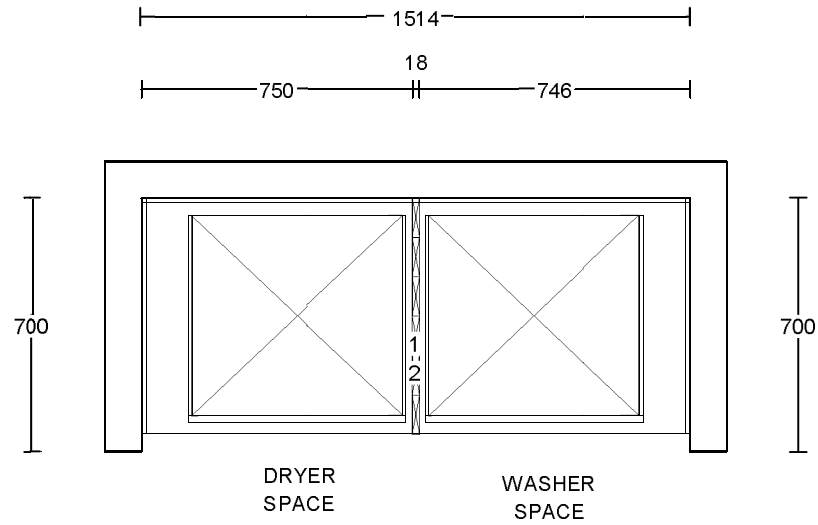

650mm DEEP WORKTOPS

PLEASE CHECK &  
CONFIRM DIMENSIONS  
& LAYOUT ON SITE  
BEFORE ORDERING  
CABINETS

Client:	BLOOR HOMES	Drawing No:	724216U_	<b>Symphony</b> <sup>®</sup>
Site:	BLOOR 2022	Revision No:		
House Type:	CLASSIC 481 HARWOOD - UTILITY	Scale:	Scale-to-fit	
House Type 2:	EXCLUSIVE			

THIS DRAWING AND THE COPYRIGHT THEREIN IS THE PROPERTY OF THE SYMPHONY GROUP PLC. THIS DRAWING IS ISSUED ON THE CONDITION THAT IT MUST NOT BE USED, COPIED OR EXHIBITED WITHOUT THE WRITTEN PERMISSION OF THE SYMPHONY GROUP PLC. ANY COMPONENTS OR ARTICLES MADE IN ACCORDANCE WITH THIS DRAWING MUST NOT BE USED FOR ANY OTHER PURPOSE THAN FOR WHICH THE DRAWING IS ISSUED.

THIS PLAN IS OFFERED AS A GUIDE ONLY FOR APPROVAL BY OUR CUSTOMER. NO RESPONSIBILITY IS UNDERTAKEN FOR ITS ACCURACY IN RELATION TO ORDERS PLACED FOR THE FITTING OF OUR GOODS WITHIN THE DIMENSIONS SHOWN.

**SCHEDULE &  
CUBIC CAPACITY**



Client Name: BLOOR HOMES Site Name: BLOOR 2022  
CLASSIC ISSUE 4

House Type: CLASSIC 481 HARWOOD - UTILITY  
EXCLUSIVE

Drawing No: 724216U\_ Revision No:  
Date Drawn: Fri, Nov 25, 2022 Revision Date:  
Designed By: CARA NORTCLIFF Quote No:

Items on Plan:		Default Style				
Plan No.	Qty	Code	Hdg	Description	Dims	CC (M3)
1	1	BBU6592R		Replacement End Matched Base Blender	650/920	

**Total cubic metres of  
storage**

Worktop Details:		Default Style				
Plan No.	Qty	Code		Description	Dims	
2	1	PWT		40mm PVC Edged / 40mm Premium / 30mm Hi Def Worktop	1600/650	
	1	PFUP3095		Laminate Upstand	3050/95	

Accessories and Trims:		Default Style				
	Qty	Code		Description	Dims	
	1	RUNITPROTECT		Kitchen Protective Material		

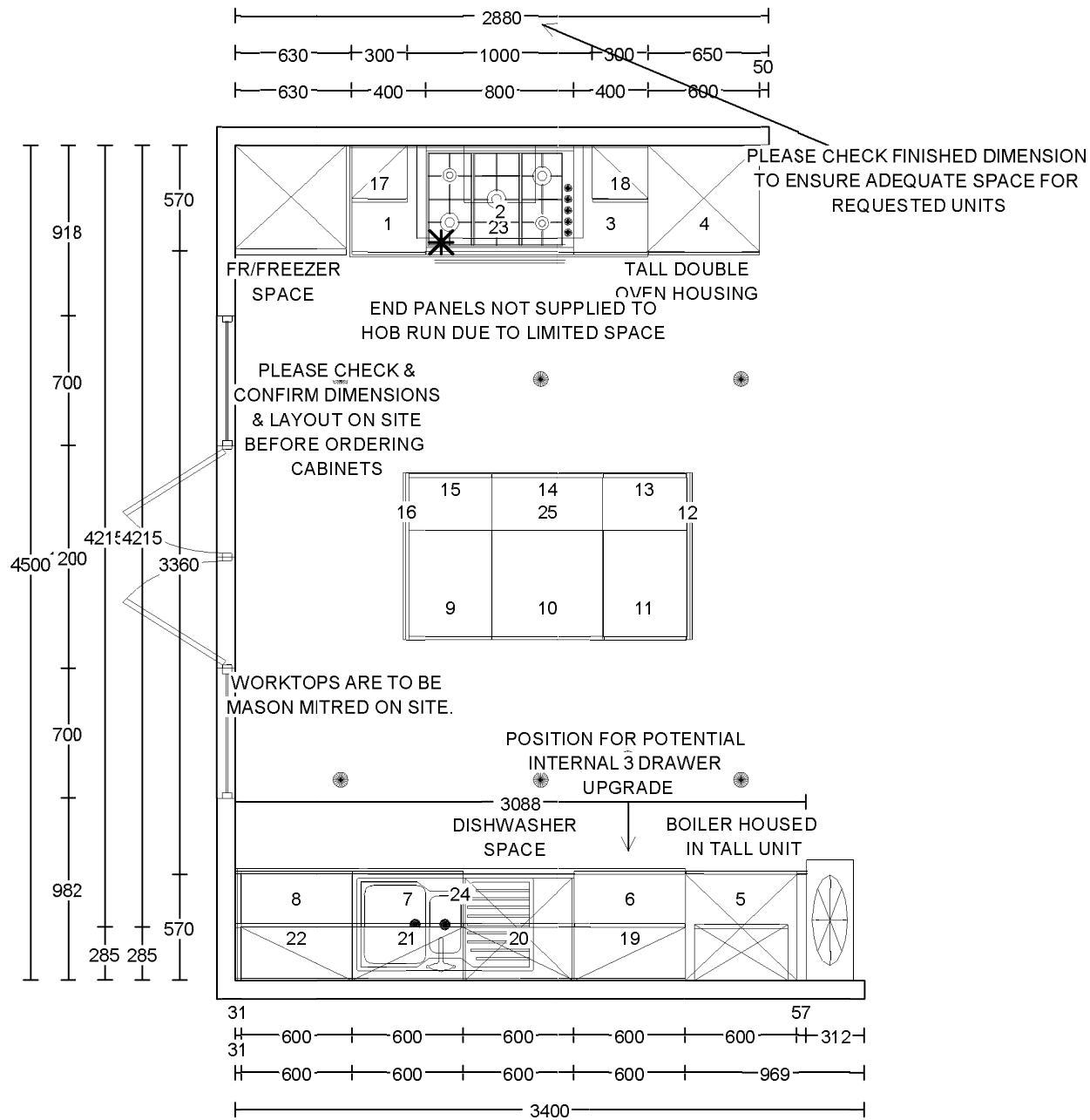

Client:	BLOOR HOMES
Site:	BLOOR 2022
House Type:	CLASSIC 481 HARWOOD - EXC UTILITY
House Type 2:	STANDARD PAN DRAWER

Drawing No:	724213_A
Revision No:	A
Scale:	Scale-to-fit



THIS DRAWING AND THE COPYRIGHT THEREIN IS THE PROPERTY OF THE SYMPHONY GROUP PLC. THIS DRAWING IS ISSUED ON THE CONDITION THAT IT MUST NOT BE USED, COPIED OR EXHIBITED WITHOUT THE WRITTEN PERMISSION OF THE SYMPHONY GROUP PLC. ANY COMPONENTS OR ARTICLES MADE IN ACCORDANCE WITH THIS DRAWING MUST NOT BE USED FOR ANY OTHER PURPOSE THAN FOR WHICH THE DRAWING IS ISSUED.

THIS PLAN IS OFFERED AS A GUIDE ONLY FOR APPROVAL BY OUR CUSTOMER. NO RESPONSIBILITY IS UNDERTAKEN FOR ITS ACCURACY IN RELATION TO ORDERS PLACED FOR THE FITTING OF OUR GOODS WITHIN THE DIMENSIONS SHOWN.



**SCHEDULE &  
CUBIC CAPACITY**



Client Name:	BLOOR HOMES	Site Name:	BLOOR 2022 CLASSIC ISSUE 4
House Type:	CLASSIC 481 HARWOOD - EXC UTILITY STANDARD PAN DRAWER		
Drawing No:	724213_A	Revision No:	A
Date Drawn:	Fri, Jul 15, 2022	Revision Date:	14.7.22
Designed By:	CARA NORTCLIFF	Quote No:	

Items on Plan:

Default Style

Plan No.	Qty	Code	Hdg	Description	Dims	CC (M3)
1	1	BU46F	L	Base Unit FH	400/600/870	0.13
2	1	PD86D2IDT		2 Pan Drawer Unit w/Int. Top Drawer	800/600/870	0.26
2.1	1	HOBSHIELD8		Hobshield	800	
3	1	BU46F	R	Base Unit FH	400/600/870	0.13
4	1	OH663A	R	Dbl Oven Hsg. (3A)	600/600/2100	0.28
5	1	LU66	L	Larder Unit (70/30 Split)	600/600/2100	0.52
6	1	BU66F	L	Base Unit FH	600/600/870	0.20
7	1	SU66SLF	L	Sink Unit FH w/Sink Liner	600/600/870	0.20
8	1	BU66F	R	Base Unit FH	600/600/870	0.20
9	1	BU456F	L	Base Unit FH	450/600/870	0.14
10	1	BU66F	R	Base Unit FH	600/600/870	0.20
11	1	BU456F	R	Base Unit FH	450/600/870	0.14
12	1	BBBP992C		Carcase Matched Breakfast Bar Back Panel	900/920	
13	1	BU453F	L	Reduced Depth Base Unit FH	450/300/870	0.07
14	1	BU63F	L	Reduced Depth Base Unit FH	600/300/870	0.10
15	1	BU453F	R	Reduced Depth Base Unit FH	450/300/870	0.07
16	1	BBBP992C		Carcase Matched Breakfast Bar Back Panel	900/920	
17	1	WU372	L	Wall Unit	300/300/724	0.05
18	1	WU372	R	Wall Unit	300/300/724	0.05
19	1	WU672	L	Wall Unit	600/300/724	0.10
20	1	WU672	R	Wall Unit	600/300/724	0.10
21	1	WU672	L	Wall Unit	600/300/724	0.10
22	1	WU672	R	Wall Unit	600/300/724	0.10
	1	BWU390C		Carcase Matched Wall Blender (For Filler)	307/920	
	1	CONPLINTHC		Carcase Matched Continuous Plinth (For Tall Filler)	2600	

**Total cubic metres of storage 3.14**

Worktop Details: Default Style

<b>Plan No.</b>	<b>Qty</b>	<b>Code</b>	<b>Description</b>	<b>Dims</b>
23	1	PWT	40mm PVC Edged / 40mm Premium / 30mm Hi Def Worktop	1628/600
24	1	PWT	40mm PVC Edged / 40mm Premium / 30mm Hi Def Worktop	2500/600
25	1	DPWT	40mm Double PVC Edged / 40mm Premium / 30mm Hi Def Worktop	1556/900
	1	PFUP3095	Laminate Upstand	3050/95
	1	PFUP3095	Laminate Upstand	3050/95

Accessories and Trims:

Default Style

<b>Qty</b>	<b>Code</b>	<b>Description</b>	<b>Dims</b>
2	BRKPLINTH	Plinth Corner Bracket (Pack of 2)	
4	CONPLINTHC	Carcase Matched Continuous Plinth w/Plinth Seal	2600
1	CTRAYVINT8	Standard Pan Drawer Internal Cutlery Tray	800
2	FITFACTOR	FITFACTOR	
2	RUNITPROTECT	Kitchen Protective Material	
1	STSBACK900	Stainless Steel Splashback 900 X	750
1	VENTGRILL200	Ventilation Grill - Flowrate	200cm2

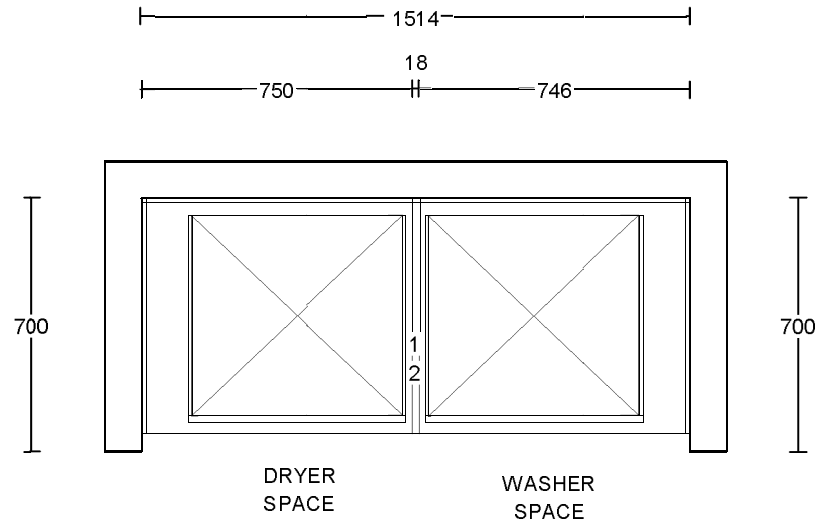

650mm DEEP WORKTOPS

PLEASE CHECK &  
CONFIRM DIMENSIONS  
& LAYOUT ON SITE  
BEFORE ORDERING  
CABINETS

Client:	BLOOR HOMES	Drawing No:	724213U_	<b>Symphony</b> <sup>®</sup>
Site:	BLOOR 2022	Revision No:		
House Type:	CLASSIC 481 HARWOOD - UTILITY	Scale:	Scale-to-fit	
House Type 2:	STANDARD PAN DRAWER			

THIS DRAWING AND THE COPYRIGHT THEREIN IS THE PROPERTY OF THE SYMPHONY GROUP PLC. THIS DRAWING IS ISSUED ON THE CONDITION THAT IT MUST NOT BE USED, COPIED OR EXHIBITED WITHOUT THE WRITTEN PERMISSION OF THE SYMPHONY GROUP PLC. ANY COMPONENTS OR ARTICLES MADE IN ACCORDANCE WITH THIS DRAWING MUST NOT BE USED FOR ANY OTHER PURPOSE THAN FOR WHICH THE DRAWING IS ISSUED.

THIS PLAN IS OFFERED AS A GUIDE ONLY FOR APPROVAL BY OUR CUSTOMER. NO RESPONSIBILITY IS UNDERTAKEN FOR ITS ACCURACY IN RELATION TO ORDERS PLACED FOR THE FITTING OF OUR GOODS WITHIN THE DIMENSIONS SHOWN.

**SCHEDULE &  
CUBIC CAPACITY**



Client Name:	BLOOR HOMES	Site Name:	BLOOR 2022 2018 - LEVEL 2 ISSUE 4
House Type:	CLASSIC 481 HARWOOD - UTILITY STANDARD PAN DRAWER		
Drawing No:	724213U_	Revision No:	
Date Drawn:	Fri, Nov 25, 2022	Revision Date:	
Designed By:	CARA NORTCLIFF	Quote No:	

Items on Plan: Default Style

Plan No.	Qty	Code	Hdg	Description	Dims	CC (M3)
1	1	BBU6592C		Carcase Matched Base Blender	650/920	

**Total cubic metres of  
storage**

Worktop Details: Default Style

Plan No.	Qty	Code	Description	Dims
2	1	PWT	40mm PVC Edged / 40mm Premium / 30mm Hi Def Worktop	1600/650
	1	PFUP3095	Laminate Upstand	3050/95

Accessories and Trims: Default Style

Qty	Code	Description	Dims
1	RUNITPROTECT	Kitchen Protective Material	

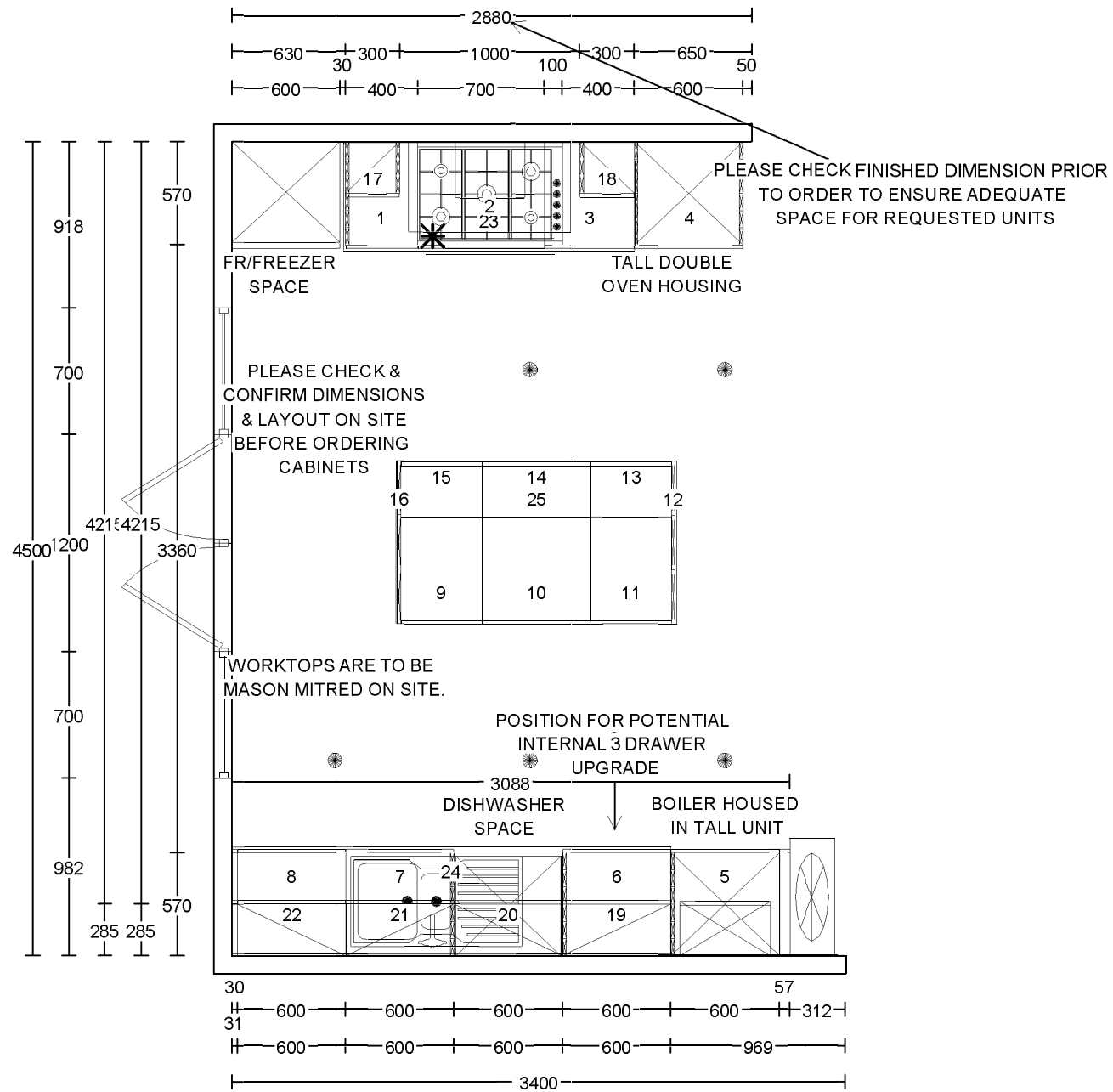

Client:	BLOOR HOMES	Drawing No:	724215_A
Site:	BLOOR 2022	Revision No:	A
House Type:	CLASSIC 481 HARWOOD - EXC UTILITY	Scale:	Scale-to-fit
House Type 2:	UPGRADE PAN DRAWER		

THIS DRAWING AND THE COPYRIGHT THEREIN IS THE PROPERTY OF THE SYMPHONY GROUP PLC. THIS DRAWING IS ISSUED ON THE CONDITION THAT IT MUST NOT BE USED, COPIED OR EXHIBITED WITHOUT THE WRITTEN PERMISSION OF THE SYMPHONY GROUP PLC. ANY COMPONENTS OR ARTICLES MADE IN ACCORDANCE WITH THIS DRAWING MUST NOT BE USED FOR ANY OTHER PURPOSE THAN FOR WHICH THE DRAWING IS ISSUED.		THIS PLAN IS OFFERED AS A GUIDE ONLY FOR APPROVAL BY OUR CUSTOMER. NO RESPONSIBILITY IS UNDERTAKEN FOR ITS ACCURACY IN RELATION TO ORDERS PLACED FOR THE FITTING OF OUR GOODS WITHIN THE DIMENSIONS SHOWN.	
--	--	--	--



**SCHEDULE &  
CUBIC CAPACITY**



Client Name:	BLOOR HOMES	Site Name:	BLOOR 2022 CLASSIC ISSUE 4
House Type:	CLASSIC 481 HARWOOD - EXC UTILITY UPGRADE PAN DRAWER		
Drawing No:	724215_A	Revision No:	A
Date Drawn:	Fri, Jul 15, 2022	Revision Date:	14.7.22
Designed By:	CARA NORTCLIFF	Quote No:	

Items on Plan:

Default Style

Plan No.	Qty	Code	Hdg	Description	Dims	CC (M3)
1	1	BU46FGL	L	Base Unit FH (LH End)	400/600/870	0.13
2	1	PD86D2IDT		2 Pan Drawer Unit w/Int. Top Drawer	800/600/870	0.26
2.1	1	HOBSHIELD8		Hobshield	800	
3	1	BU56F	R	Base Unit FH	500/600/870	0.16
4	1	OH663AG2	R	Dbl Oven Hsg. (3A) (2 Ends)	600/600/2100	0.28
5	1	LU66GR	L	Larder Unit (70/30 Split) (RH End)	600/600/2100	0.52
6	1	BU66FGR	L	Base Unit FH (RH End)	600/600/870	0.20
7	1	SU66SLFGL	L	Sink Unit FH w/Sink Liner (LH End)	600/600/870	0.20
8	1	BU66F	R	Base Unit FH	600/600/870	0.20
9	1	BU456F	L	Base Unit FH	450/600/870	0.14
10	1	BU66F	R	Base Unit FH	600/600/870	0.20
11	1	BU456F	R	Base Unit FH	450/600/870	0.14
12	1	BBBP992R		Replacement End Matched Breakfast Bar Back Panel	900/920	
13	1	BU453F	L	Reduced Depth Base Unit FH	450/300/870	0.07
14	1	BU63F	L	Reduced Depth Base Unit FH	600/300/870	0.10
15	1	BU453F	R	Reduced Depth Base Unit FH	450/300/870	0.07
16	1	BBBP992R		Replacement End Matched Breakfast Bar Back Panel	900/920	
17	1	WU372G2	L	Wall Unit (2 Ends)	300/300/724	0.05
18	1	WU372GL	R	Wall Unit (LH End)	300/300/724	0.05
19	1	WU672	L	Wall Unit	600/300/724	0.10
20	1	WU672	R	Wall Unit	600/300/724	0.10
21	1	WU672	L	Wall Unit	600/300/724	0.10
22	1	WU672	R	Wall Unit	600/300/724	0.10
	1	CONPLINTHR		Replacement End Matched Continuous Plinth (For Tall Filler)	2600	
	1	BWU390R		Replacement End Matched Wall Blender (For Filler)	307/970	
	1	BWU390R		Replacement End Matched Wall Blender (For Filler)	307/970	

**Total cubic metres of storage**

**3.17**

Worktop Details:

Default Style

<b>Plan No.</b>	<b>Qty</b>	<b>Code</b>	<b>Description</b>	<b>Dims</b>
23	1	PWT	40mm PVC Edged / 40mm Premium / 30mm Hi Def Worktop	1610/600
24	1	PWT	40mm PVC Edged / 40mm Premium / 30mm Hi Def Worktop	2500/600
25	1	DPWT	40mm Double PVC Edged / 40mm Premium / 30mm Hi Def Worktop	1556/900
	1	PFUP3095	Laminate Upstand	3050/95
	1	PFUP3095	Laminate Upstand	3050/95

Accessories and Trims:

Default Style

<b>Qty</b>	<b>Code</b>	<b>Description</b>	<b>Dims</b>
4	CONPLINTHR	Replacement End Matched Continuous Plinth w/Plinth Seal	2600
1	CTRAYVINT8	Standard Pan Drawer Internal Cutlery Tray	800
2	FITFACTOR	FITFACTOR	
2	RUNITPROTECT	Kitchen Protective Material	
1	STSBACK900	Stainless Steel Splashback 900 X	750
1	VENTGRIDGR	Aeration Grid Grey	510/45/15

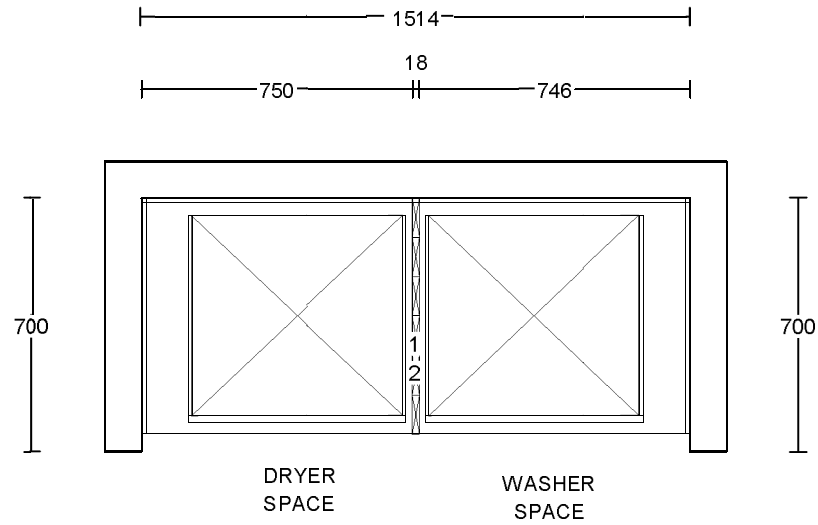

650mm DEEP WORKTOPS

PLEASE CHECK &  
 CONFIRM DIMENSIONS  
 & LAYOUT ON SITE  
 BEFORE ORDERING  
 CABINETS

Client:	BLOOR HOMES	Drawing No:	724215U_	<b>Symphony</b> <sup>®</sup>
Site:	BLOOR 2022	Revision No:		
House Type:	CLASSIC 481 HARWOOD - UTILITY	Scale:	Scale-to-fit	
House Type 2:	UPGRADE PAN DRAWER			

THIS DRAWING AND THE COPYRIGHT THEREIN IS THE PROPERTY OF THE SYMPHONY GROUP PLC. THIS DRAWING IS ISSUED ON THE CONDITION THAT IT MUST NOT BE USED, COPIED OR EXHIBITED WITHOUT THE WRITTEN PERMISSION OF THE SYMPHONY GROUP PLC. ANY COMPONENTS OR ARTICLES MADE IN ACCORDANCE WITH THIS DRAWING MUST NOT BE USED FOR ANY OTHER PURPOSE THAN FOR WHICH THE DRAWING IS ISSUED.

THIS PLAN IS OFFERED AS A GUIDE ONLY FOR APPROVAL BY OUR CUSTOMER. NO RESPONSIBILITY IS UNDERTAKEN FOR ITS ACCURACY IN RELATION TO ORDERS PLACED FOR THE FITTING OF OUR GOODS WITHIN THE DIMENSIONS SHOWN.



**SCHEDULE &  
CUBIC CAPACITY**



Client Name:	BLOOR HOMES	Site Name:	BLOOR 2022 2018 - LEVEL 2 ISSUE 4
House Type:	CLASSIC 481 HARWOOD - UTILITY UPGRADE PAN DRAWER		
Drawing No:	724215U_	Revision No:	
Date Drawn:	Fri, Nov 25, 2022	Revision Date:	
Designed By:	CARA NORTCLIFF	Quote No:	

Items on Plan:	Default Style					
<b>Plan No.</b>	<b>Qty</b>	<b>Code</b>	<b>Hdg</b>	<b>Description</b>	<b>Dims</b>	<b>CC (M3)</b>
1	1	BBU6592R		Replacement End Matched Base Blender	650/920	

**Total cubic metres of  
storage**

Worktop Details:	Default Style					
<b>Plan No.</b>	<b>Qty</b>	<b>Code</b>		<b>Description</b>	<b>Dims</b>	
2	1	PWT		40mm PVC Edged / 40mm Premium / 30mm Hi Def Worktop	1600/650	
	1	PFUP3095		Laminate Upstand	3050/95	

Accessories and Trims:	Default Style					
	<b>Qty</b>	<b>Code</b>		<b>Description</b>	<b>Dims</b>	
	1	RUNITPROTECT		Kitchen Protective Material		

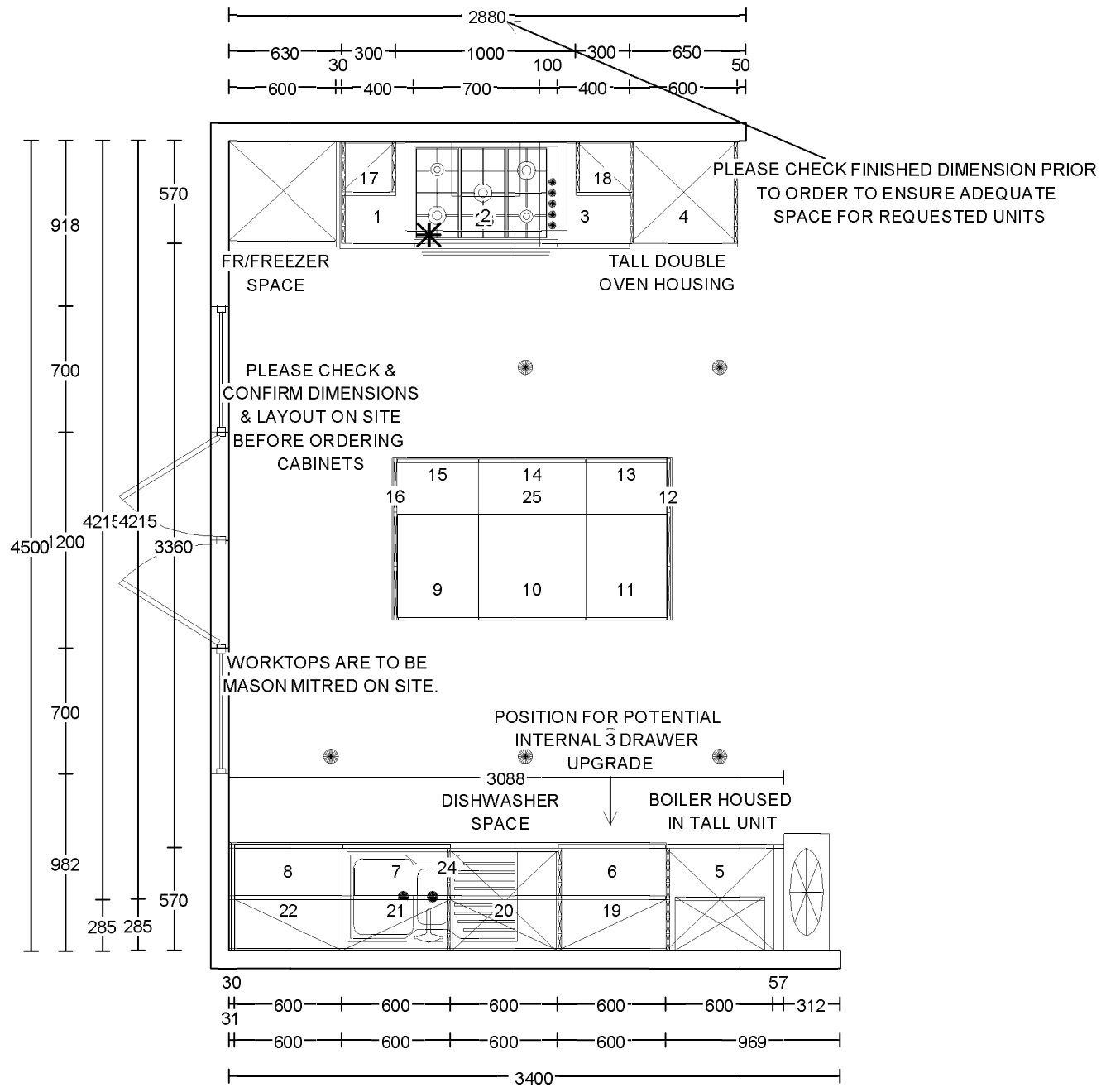

Client:	BLOOR HOMES	Drawing No:	724217__
Site:	BLOOR 2022	Revision No:	
House Type:	CLASSIC 481 HARWOOD - EXC UTILITY	Scale:	Scale-to-fit
House Type 2:	EXCLUSIVE PAN DRAWER		



THIS DRAWING AND THE COPYRIGHT THEREIN IS THE PROPERTY OF THE SYMPHONY GROUP PLC. THIS DRAWING IS ISSUED ON THE CONDITION THAT IT MUST NOT BE USED, COPIED OR EXHIBITED WITHOUT THE WRITTEN PERMISSION OF THE SYMPHONY GROUP PLC. ANY COMPONENTS OR ARTICLES MADE IN ACCORDANCE WITH THIS DRAWING MUST NOT BE USED FOR ANY OTHER PURPOSE THAN FOR WHICH THE DRAWING IS ISSUED.

THIS PLAN IS OFFERED AS A GUIDE ONLY FOR APPROVAL BY OUR CUSTOMER. NO RESPONSIBILITY IS UNDERTAKEN FOR ITS ACCURACY IN RELATION TO ORDERS PLACED FOR THE FITTING OF OUR GOODS WITHIN THE DIMENSIONS SHOWN.

**SCHEDULE &  
CUBIC CAPACITY**



Client Name:	BLOOR HOMES	Site Name:	BLOOR 2022 CLASSIC ISSUE 4
House Type:	CLASSIC 481 HARWOOD - EXC UTILITY EXCLUSIVE PAN DRAWER		
Drawing No:	724217__	Revision No:	
Date Drawn:	Wed, Mar 30, 2022	Revision Date:	
Designed By:	CARA NORTCLIFF	Quote No:	

Items on Plan:

Default Style

Plan No.	Qty	Code	Hdg	Description	Dims	CC (M3)
1	1	BU46FGL	L	Base Unit FH (LH End)	400/600/870	0.13
2	1	PD86D2IDT		2 Pan Drawer Unit w/Int. Top Drawer	800/600/870	0.26
2.1	1	HOBSHIELD8		Hobshield	800	
3	1	BU56F	R	Base Unit FH	500/600/870	0.16
4	1	OH663AG2	R	Dbl Oven Hsg. (3A) (2 Ends)	600/600/2100	0.28
5	1	LU66GR	L	Larder Unit (70/30 Split) (RH End)	600/600/2100	0.52
6	1	BU66FGR	L	Base Unit FH (RH End)	600/600/870	0.20
7	1	SU66SLFGL	L	Sink Unit FH w/Sink Liner (LH End)	600/600/870	0.20
8	1	BU66F	R	Base Unit FH	600/600/870	0.20
9	1	BU456F	L	Base Unit FH	450/600/870	0.14
10	1	BU66F	R	Base Unit FH	600/600/870	0.20
11	1	BU456F	R	Base Unit FH	450/600/870	0.14
12	1	BBBP992R		Replacement End Matched Breakfast Bar Back Panel	900/920	
13	1	BU453F	L	Reduced Depth Base Unit FH	450/300/870	0.07
14	1	BU63F	L	Reduced Depth Base Unit FH	600/300/870	0.10
15	1	BU453F	R	Reduced Depth Base Unit FH	450/300/870	0.07
16	1	BBBP992R		Replacement End Matched Breakfast Bar Back Panel	900/920	
17	1	WU372G2	L	Wall Unit (2 Ends)	300/300/724	0.05
18	1	WU372GL	R	Wall Unit (LH End)	300/300/724	0.05
19	1	WU672	L	Wall Unit	600/300/724	0.10
20	1	WU672	R	Wall Unit	600/300/724	0.10
21	1	WU672	L	Wall Unit	600/300/724	0.10
22	1	WU672	R	Wall Unit	600/300/724	0.10
	1	CONPLINTHR		Replacement End Matched Continuous Plinth (For Tall Filler)	2600	
	1	BWU390R		Replacement End Matched Wall Blender (For Filler)	307/970	
	1	BWU390R		Replacement End Matched Wall Blender (For Filler)	307/970	

## Worktop Details:

Default Style

Plan No.	Qty	Code	Description	Dims
23	1	PWT	40mm PVC Edged / 40mm Premium / 30mm Hi Def Worktop	1610/600
24	1	PWT	40mm PVC Edged / 40mm Premium / 30mm Hi Def Worktop	2500/600
25	1	DPWT	40mm Double PVC Edged / 40mm Premium / 30mm Hi Def Worktop	1556/900
	1	PFUP3095	Laminate Upstand	3050/95
	1	PFUP3095	Laminate Upstand	3050/95

## Accessories and Trims:

Default Style

Qty	Code	Description	Dims
4	CONPLINTHR	Replacement End Matched Continuous Plinth w/Plinth Seal	2600
1	CTRAYVINT8	Standard Pan Drawer Internal Cutlery Tray	800
2	FITFACTOR	FITFACTOR	
1	GLSPASH975	Glass Splashback	900/750
2	RUNITPROTECT	Kitchen Protective Material	
1	VENTGRIDGR	Aeration Grid Grey	510/45/15

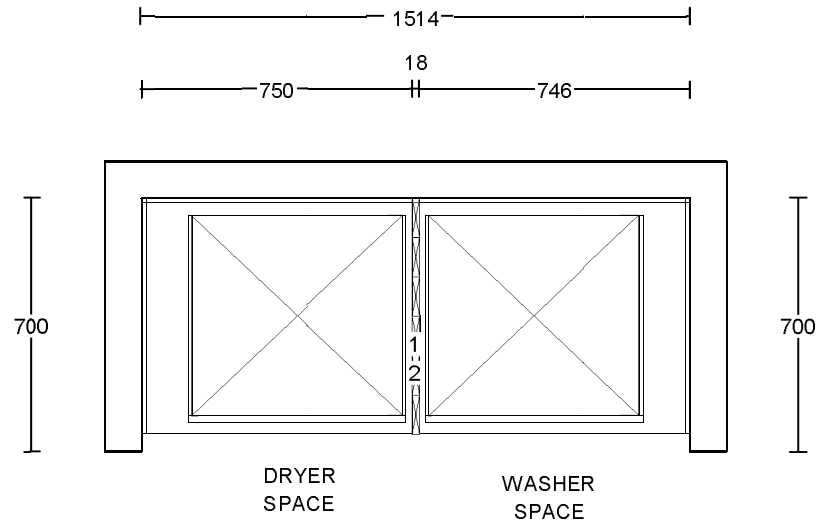

650mm DEEP WORKTOPS

PLEASE CHECK &  
CONFIRM DIMENSIONS  
& LAYOUT ON SITE  
BEFORE ORDERING  
CABINETS

Client:	BLOOR HOMES	Drawing No:	724217U_	<b>Symphony</b> <sup>®</sup>
Site:	BLOOR 2022	Revision No:		
House Type:	CLASSIC 481 HARWOOD - UTILITY	Scale:	Scale-to-fit	
House Type 2:	EXCLUSIVE PAN DRAWER			

THIS DRAWING AND THE COPYRIGHT THEREIN IS THE PROPERTY OF THE SYMPHONY GROUP PLC. THIS DRAWING IS ISSUED ON THE CONDITION THAT IT MUST NOT BE USED, COPIED OR EXHIBITED WITHOUT THE WRITTEN PERMISSION OF THE SYMPHONY GROUP PLC. ANY COMPONENTS OR ARTICLES MADE IN ACCORDANCE WITH THIS DRAWING MUST NOT BE USED FOR ANY OTHER PURPOSE THAN FOR WHICH THE DRAWING IS ISSUED.

THIS PLAN IS OFFERED AS A GUIDE ONLY FOR APPROVAL BY OUR CUSTOMER. NO RESPONSIBILITY IS UNDERTAKEN FOR ITS ACCURACY IN RELATION TO ORDERS PLACED FOR THE FITTING OF OUR GOODS WITHIN THE DIMENSIONS SHOWN.

**SCHEDULE &  
CUBIC CAPACITY**



Client Name:	BLOOR HOMES	Site Name:	BLOOR 2022 CLASSIC ISSUE 4
House Type:	CLASSIC 481 HARWOOD - UTILITY EXCLUSIVE PAN DRAWER		
Drawing No:	724217U_	Revision No:	
Date Drawn:	Fri, Nov 25, 2022	Revision Date:	
Designed By:	CARA NORTCLIFF	Quote No:	

Items on Plan:		Default Style				
Plan No.	Qty	Code	Hdg	Description	Dims	CC (M3)
1	1	BBU6592R		Replacement End Matched Base Blender	650/920	

**Total cubic metres of  
storage**

Worktop Details:		Default Style				
Plan No.	Qty	Code		Description	Dims	
2	1	PWT		40mm PVC Edged / 40mm Premium / 30mm Hi Def Worktop	1600/650	
	1	PFUP3095		Laminate Upstand	3050/95	

Accessories and Trims:		Default Style				
	Qty	Code		Description	Dims	
	1	RUNITPROTECT		Kitchen Protective Material		